

Indoor Air Quality Transmitter

AVC-M Series

Aecl[®]

■ Features

In most public space or office buildings, the air ventilation and air quality is poor. The AVC-M series can detect several important parameters of indoor air quality and environment, such as CO₂, CO, HCHO, O₂, NH₃, TVOC, PM_{2.5}, PM₁₀, temperature and humidity. Easy installation and the recommended height of installation is 1~2M above the floor level. It uses good quality sensors; such as the NDIR CO₂ sensor; electro-chemical sensor for HCHO, CO, O₂ and NH₃; laser scattering principle sensor for PM_{2.5} and PM₁₀; CMOS sensor for TVOC, temperature and humidity.

AVC-M can be used with a monitoring system, which can activate ventilation system to keep a better indoor air quality or for energy saving. It is perfect for school, library, offices, meeting room, commercial building, shopping center, train/subway station or exhibition hall, etc.

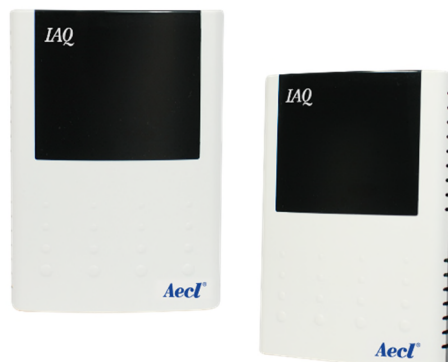

■ Dimensions

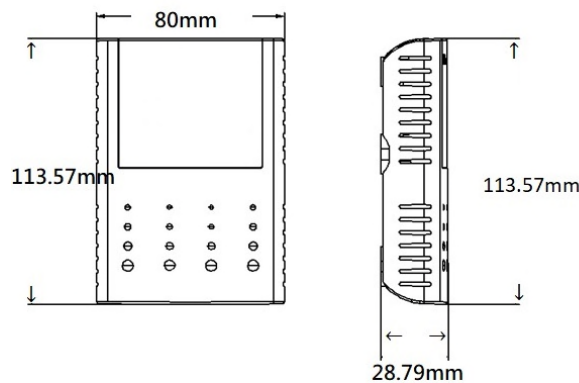

■ Specifications

General technical data	
Parameters	Temperature, Humidity, CO ₂ , CO, HCHO, TVOC, PM _{2.5} , PM ₁₀ , O ₂ , NH ₃
Signal output	RS485 or RS485 / LoRa (Peer to Peer) switchable, LoRa frequency band: 862 ~ 932 MHz ⁽¹⁾
Warm-up time	15 minutes
Operating environment	-10 ~ 50°C (14~122°F) / 0 ~ 95%RH, non-condensing
Storage temperature	-10 ~ 50°C (14~122°F)
Power supply	DC 12 ~36V, AC 24V (50/60Hz)
Power consumption	RS485: 3W (Max.); LoRa / RS485: 4.5W (Max.)
Certifications	CE, FCC
IP rating	IP30 (No protection from liquids)
Case material	Fireproof ABS
Weight	125g

Temperature Measurement		Humidity Measurement
Sensing element	CMOS sensing element	CMOS sensing element
Measurement range	-10 ~ 50°C (14~122°F)	0 ~ 95%RH
Accuracy	± 0.3°C (typical)	± 3 %RH (typical)
Resolution	0.01°C	0.01%RH
Repeatability	± 0.1°C	± 0.1%RH
Response time	5 ~ 30 sec. (τ63% · 25°C)	< 8 sec. (τ63% · 25°C)
Long-term drift	< 0.04°C/ year	< 0.5 %RH / year
CO ₂ Measurement		VOC level Measurement
Measurement principle	NDIR with automatic calibration	CMOS sensing element
Measurement range	0 ~ 9999 ppm	0 ~ 500 VOC Index points ⁽³⁾
Accuracy	0~2000 ppm (± 30ppm ± 3% of reading), 2001~9999 ppm (± 70ppm ± 3% of reading) ^{note1 and 2}	< ± 15 VOC Index points
Resolution	1 ppm	1 VOC Index points
Response time	2 minutes by 90%	< 10 sec. (τ63 %)
Repeatability	± 20 ppm+ (± reading *1%)	< ± 5 VOC Index points
Maintenance	Maintenance-free for normal indoor applications	

CO Measurement		HCHO Measurement
Measurement principle	Electro-chemical	Electro-chemical
Measurement range	0 ~ 100 ppm	0 ~ 3.00 ppm
Accuracy	± 5%	± 5%
Resolution	1 ppm	0.01 ppm
Repeatability	Reading ± 2 %	< ± 0.05 ppm
Response time	$\tau_{90} \leq 30$ sec.	$\tau_9 < 120$ sec. (HCHO: 1 ppm)
Drift	Zero: < ± 5 ppm; Span: $\leq 5\%$ reading /year	Zero: < 0.05 ppm; Span: < 20% reading /year
PM _{2.5} Measurement		PM ₁₀ Measurement
Measurement principle	Laser distributing	Laser distributing
Measurement range	0 ~ 600 µg/m ³	0 ~ 600 µg/m ³
Accuracy	0 ~ 100 µg/m ³ (± 10 µg/m ³), 100 ~ 600 µg/m ³ (± 10%)	0 ~ 100 µg/m ³ (± 10 µg/m ³), 100 ~ 600 µg/m ³ (± 10%)
Resolution	1 µg/m ³	1 µg/m ³
Response time	≤ 10 sec.	≤ 10 sec.
Maintenance	Maintenance-free for normal indoor applications	Maintenance-free for normal indoor applications
O ₂ Measurement		NH ₃ Measurement
Measurement principle	Electro-chemical	Electro-chemical
Measurement range	0 ~ 30%	0 ~ 50 ppm
Accuracy	Full scale ± 5%	± 5%
Resolution	0.01%	0.1 ppm
Repeatability	Reading ± 5%	± 10%
Response time	$\tau_{90} \leq 15$ sec.	$\tau_{90} \leq 90$ sec.
Drift	< 2% /month ⁽²⁾	Zero: < ± 10 ppm /year; Span: < 2% reading /month

Note 1: In normal IAQ applications. Accuracy is defined after minimum 3 weeks of continuous operation with ABC. However, some industrial applications do require maintenance.

Note 2: Accuracy is specified at room temperature +25°C and at normal pressure 101.3 kPa. Specification is referenced to certified calibration mixtures. Uncertainty of calibration gas mixtures (+-1% currently) is to be added to the specified accuracy for absolute measurements.

- (1) The frequency channels will be differed by country and this frequency can be configured accordingly from 862 to 932Hz.
- (2) It is recommended to perform calibration at least every 6 months. Meanwhile, for the device installed in the environment with extreme condition, quarterly calibration would be necessary. When sensor is aging (lifespan of sensor is usually 12 months), it might cause sensor drift.
- (3) VOC index points: The value 100 refers to the typical indoor gas composition over the past 24 h. While values between 100 and 500 indicate a deterioration, values between 0 and 100 inform about improvement of the air quality.

■ Ordering information

AVC-M□□□□□□-M

Code 1	Gas type
X	No
3	CO ₂
5	H+T
A	H+T+CO ₂

Code 2	Gas type
X	No
2	PM _{2.5}
5	PM ₁₀
9	TVOC
A	PM _{2.5} +PM ₁₀
B	PM _{2.5} +TVOC
C	PM ₁₀ +TVOC
D	PM _{2.5} +PM ₁₀ +TVOC

Code 3	Gas type
X	No
0	O ₂
1	CO
4	NH ₃
8	HCHO
A	CO+O ₂
B	CO+NH ₃
C	CO+HCHO

Code 4	Installation
W	Wall mount

Code 5	Signal output
4	RS485
6	LoRa / RS485

Code 6	Display
X	No